



Electrolux
PROFESSIONAL

**Modular Cooking Range Line
900XP 1200mm Electric Fry Top HP,
Smooth and Ribbed scratch resistant
chromium Plate**

ITEM # _____

MODEL # _____

NAME # _____

SIS # _____

AIA # _____



391405 (E9IIMDAOMIA)

Large electric fry top with 2/3 smooth and 1/3 ribbed Scratch Resistant NitroChrome3 cooking plate, horizontal, thermostatic control, scraper included - HP (availability from Q2 2020)

Short Form Specification

Item No. _____

2/3 smooth and 1/3 ribbed cooking scratch resistant chromium surface. Heating elements positioned beneath the cooking plate to ensure very fast heat-up time to maximum temperature and quick temperature recovery. High precision thermostatic control. To be installed on open base installations, bridging supports or cantilever systems. Removable drawers below the cooking surface for the collection of grease and fat. Body and work top of unit entirely in stainless steel with Scotch Brite finish. Extra strength work top in heavy duty 2 mm stainless steel. Right-angled side edges to allow flush-fitting junction between units.

Main Features

- Exclusive IcyHot installation: combine the Fry Top HP with the dual temperature refrigerated/freezer base HP and obtain a single appliance which simultaneously increases productivity and facilitates cooking and storage operations.
- Unit to be mounted on open base cupboards, bridging supports or cantilever systems.
- Infrared heating elements mounted below the cooking surface.
- Safety thermostat and thermostatic control.
- Two large drain holes on cooking surface permits the draining of fat into two separate 3 liter collectors placed under the cooking surface.
- Stainless steel high splash guards on the rear and sides of cooking surface.
- The special design of the control knob system guarantees against water infiltration.
- IPX5 water protection.
- Units have 4 independent controls to regulate temperature of the cooking surface.
- Scratch resistant cooking surface thanks to a special treatment of the chromium plate.
- Easy to clean and corrosion resistant chromium surface.
- Temperature range from 120° up to 280°C.
- Suitable for countertop installation.

Construction

- Cooking surface 2/3 smooth and 1/3 ribbed.
- All exterior panels in Stainless Steel with Scotch Brite finishing.
- Model has right-angled side edges to allow flush fitting joints between units, eliminating gaps and possible dirt traps.
- Unit is 930 mm deep to give a larger working surface area.
- AISI 304 stainless steel worktop, 2mm thick.
- Non-scratch cooking surface 20mm thick for optimum grilling results and ease of use.

Included Accessories

- 1 of Scraper for smooth plate fry tops PNC 164255
- 1 of Scraper for ribbed plate fry tops - kit includes knife blades for both smooth and ribbed surface PNC 206420

Optional Accessories

- Scraper for smooth plate fry tops PNC 164255
- Junction sealing kit PNC 206086
- Support for bridge type installation, 1200mm PNC 206139
- Support for bridge type installation, 1400mm PNC 206140
- Support for bridge type installation, 1600mm PNC 206141
- Frontal kicking strip, 1200mm (not for refr-freezer base) PNC 206178

APPROVAL: _____



Experience the Excellence
www.electroluxprofessional.com

- Stopper for 900 fry top with horizontal plate PNC 206296
- Chimney upstand, 400mm PNC 206303
- Back handrail 1200 mm PNC 206309
- Water drain for fry tops HP PNC 206345
- Grease/oil kit container for 700 line frytops (half and module) and 900 line frytops (module) PNC 206346
- Scraper for ribbed plate fry tops - kit includes knife blades for both smooth and ribbed surface PNC 206420
- Cloche for fry tops PNC 206455
- Side handrail-right/left hand (900XP) PNC 216044
- Frontal handrail, 1200mm PNC 216049
- Frontal handrail, 1600mm PNC 216050

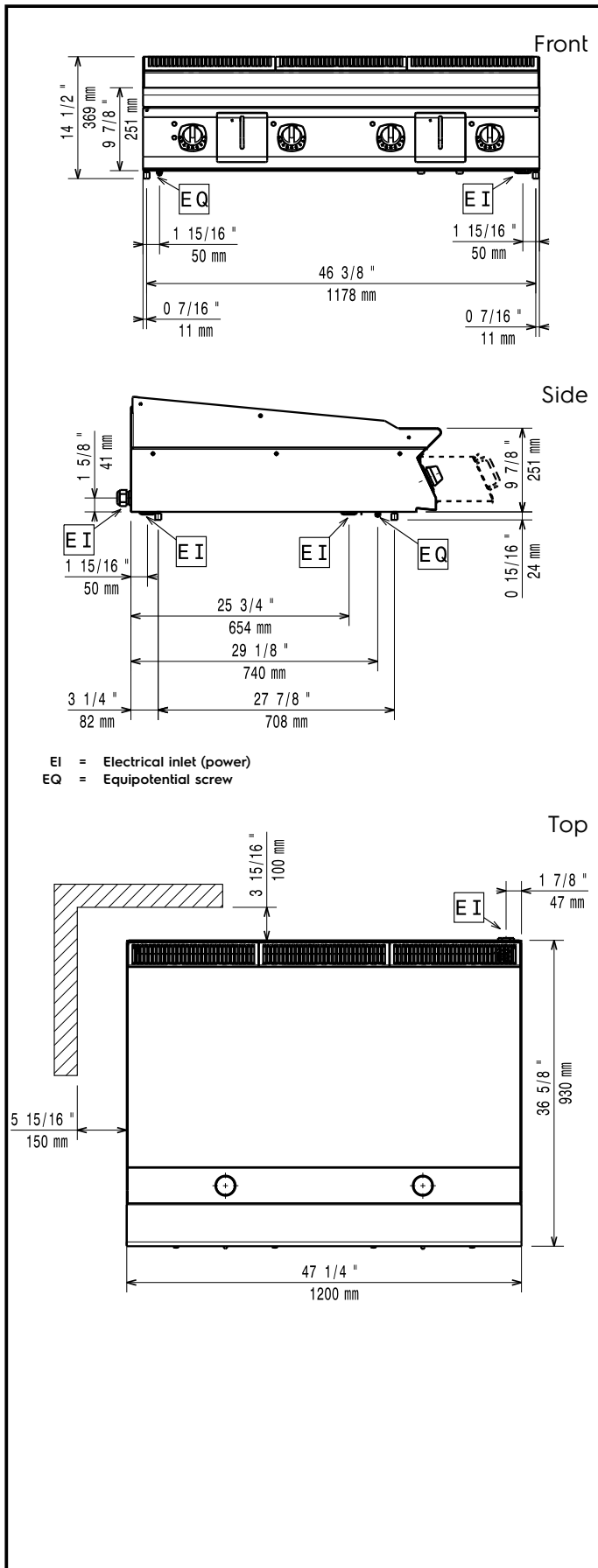

Electric

Supply voltage:	391405 (E9IIMDAOMIA)	380-400 V/3 ph/50/60 Hz
Total Watts:		ISO 9001; ISO 14001 kW
Predisposed for:		380-400V 3- 50/60Hz
		18-20kW

Key Information:

Configuration:	Top
Cooking surface width:	1194 mm
Cooking surface depth:	610 mm
External dimensions, Width:	1200 mm
External dimensions, Depth:	930 mm
External dimensions, Height:	250 mm
Net weight:	150 kg
Shipping weight:	189 kg
Shipping height:	580 mm
Shipping width:	1020 mm
Shipping depth:	1260 mm
Shipping volume:	0.75 m ³

If appliance is set up or next to or against temperature sensitive furniture or similar, a safety gap of approximately 150 mm should be maintained or some form of heat insulation fitted.